

CAT-200B Repeater Controller

GMRS REPEATER

Computer Automation Technology, Inc.

4631 N.W. 31st Avenue, Suite 142
Fort Lauderdale, Florida 33309
Phone: (954) 978-6171 Fax: (561) 488-2894
Internet: <http://www.catauto.com>

Table of Contents

Chapter		Page
1.	Introduction and Specifications	1-1
2.	System Configuration	2-1
3.	Repeater Control (DTMF)	3-1
4.	Repeater Operation	4-1
5.	Repeater Programming (DTMF)	5-1
6.	Interfacing to Other Equipment	6-1
7.	Weather Station Interface	7-1
8.	Vocabulary Word List	8-1
9.	Drawings	9-1
10.	Schematics	10-1
11.	Parts List	11-1
12.	Remote Transceiver Weather Station	12-1
13.	CI-200 Interface Module	13-1
14.	DL-1000C Audio Delay Module	14-1
15.	RLS-1000B Remote Link Switch	15-1

REVISED 06/25/03 (V1.12)

Chapter 1 - Introduction and Specifications

Congratulations on your purchase of the CAT-200B Repeater Controller. Programming the CAT-200B is a snap, with its carefully structured uniform programming commands. The manual is easy to follow and the voice synthesizer interacts with you during control and programming operation.

Voice Synthesizer

A vocabulary base of 335 words is available to ID your repeater and make voice announcements.

CW ID

The controller will switch to CW when a repeater user talks over the voice ID. When the voice ID, message #1 is erased, the controller will ID in CW only.

Courtesy Tone

Separate courtesy tones denote repeater and link receiver activity.

Link Control

The CAT-200B will support a link transceiver. You can enable the transceiver or just the receiver to monitor activity on the transceiver frequency while you use the repeater. The CAT-200B will suppress your repeater identification from being transmitted on the transceiver frequency if Zone 2 Channel 5 is disabled.

Weather Station Interface

Provide timely weather announcements on your repeater system. Connect a Peet Brothers Ultimeter ® U-100, U-800 or U-2000 Weather Station to the serial port of the CAT-200B. Integrate temperature, wind speed, direction and rainfall into any of the CAT-200B voice messages. Program a special weather report message as part of your identification.

Beacon Mode

When the repeater is inactive and Zone 4 Channel 2 is enabled, the CAT-200B will key the transmitter and announce voice message 7. This message will repeat at a rate determined by the Beacon timer.

User Function Output Switches

Four open collector user function output switches control equipment at your repeater site. These switches are controlled manually by DTMF commands or from within a voice message. They can be made to turn OFF, ON or Momentarily change state, any time you choose.

User Function Inputs

Four inputs activated by a voltage change from other equipment at the repeater site, causes the CAT-200B to activate voice messages as alarms or announcements. The messages will continue to repeat as long as the respective logic input remains active high. The logic input message timer controls the time between announcements. Information about the repeater site will be instantly available.

DTMF Keypad Test

A DTMF keypad test will read back the numbers decoded in a synthesized voice.

Specifications

Microprocessor	P80C51RD2
Memory	25C320
Voice Synthesizer	Texas Instruments MSP53C391NI2D
Voice Vocabulary	335 Words
DTMF Receiver	MT8870
Operating Temperature	-15 to +55 degrees C
Call Letter ID	Buffer size VOICE (15) - CW (16)
User Function Outputs	(4) Switch 40VDC @ 50mA.
Logic Inputs	(4) 10K ohm input impedance Low (0 to 0.8VDC) High (2.4 to 15VDC)
Logic Outputs	Open Collector Relay Driver (28VDC at 50mA)
Audio Input	Receiver 0.2 - 2VAC adjustable 10K ohms
Audio Output	Transmitter 2VAC adjustable 600 ohms
Power	+9 to +12VDC at 50mA
Size	4.5" X 5.0"
Warranty	Limited one year, parts and labor.

FCC Part 15 RF Interference

When installed in the RME-200 rack mount enclosure, the CAT-200B has been tested and found to meet the standards for a Class A digital device, as specified in Part 15 of the FCC Rules. These specifications are designed to provide reasonable protection against such interference in a commercial installation. However, there is no guarantee that interference will not occur in a particular installation.

Chapter 2 - System Configuration

Repeater With Fixed Frequency Transceiver

In this configuration the CAT-200B supports a repeater with a CTCSS decoder and a transceiver on a fixed frequency.

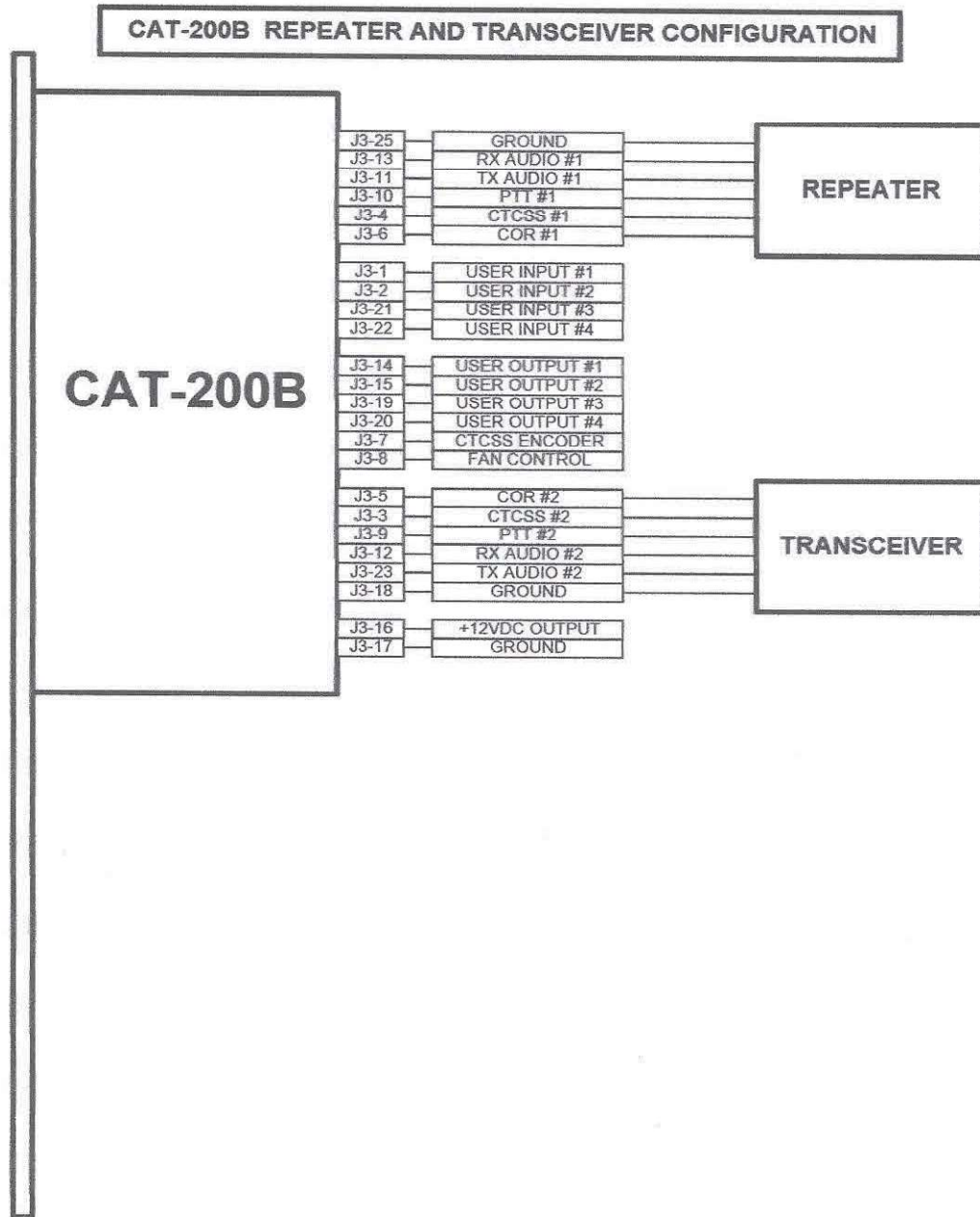

Figure 2-1

Dip Switch

An eight-position dipswitch configures various functions of the CAT-200B.

NOTE: Anytime a dipswitch is changed, DC power must be cycled for the CAT-200B controller to read the new setting.

Switch 1 This switch determines Repeater COR input logic. Switch #1 should be ON if the repeater receiver's COR is an active low and OFF if COR is active high.

Switch 2 This switch determines Repeater CTCSS input logic. Switch #2 should be ON if the repeater receiver's CTCSS is an active low and OFF if CTCSS is active high.

Switch 3 This switch determines Link COR input logic. This switch should be ON if the link receiver's COR is an active low and OFF if COR is active high.

Switch 4 This switch determines Link CTCSS input logic. Switch #4 should be ON if the link receiver's CTCSS is an active low and OFF if CTCSS is active high.

Switch 5 This switch determines if the CAT-200B is in the Repeater or Remote Transceiver Weather Station mode. This switch should be OFF if the CAT-200B is configured as a repeater controller. If the CAT-200B is configured as a remote weather station controller this switch should be ON. Consult Chapter 12 for a description of the changes in operation.

Switch 6 This switch is used to identify that the CI-200 Interface module is connected to the CAT-200B.

Switch 7 This switch is used to initialize the CAT-200B. Set this switch to ON. Cycle the power OFF and back ON. During power-up, the memory will be flushed and reloaded with default values. The voice will say: "RESET SYSTEM OK." Set dipswitch #7 to the OFF position.

Switch 8 This switch is used to program a new un-lock number. Set switch #8 to ON. The voice will say: "ENTER CONTROL." After the seven-digit unlock number is entered, set switch #8 to OFF. This switch is also used to activate the RS-232 port when the CI-200 is connected. Turn the power off set dipswitch #8 to on and apply power to the CAT-200B.

Chapter 3 - Repeater Control

The CAT-200B has 4 Zones for a total of 32 remote control channels. These channels can be manually controlled by DTMF commands on the repeater input.

Interrogation of Repeater Control Status by Radio

Key-up and send the control operator code [100] followed by the zone number and a zero. Un-key and the voice will read back the channels that are turned on in that zone. Example: Read Zone 2 channel status. If all the channels are turned off, the voice will say: "CLEAR."

Control Operator Code  100

Key-up and send: 100 2 0

 Zone (2)
Read Channel Status (0)

Un-key and the voice will say: "ONE FOUR EIGHT"

Changing Repeater Control Status by Radio

To change the status of a channel, key-up and send the control operator code [100] followed by the zone number, channel number and a [1] to turn the channel ON or a [0] to turn the channel OFF. Un-key and the voice will read back the zone, channel number and control activity. The voice will say: "ONE ONE ON." or "THREE FIVE OFF." Example: With a control operator prefix of 100, turn Zone 2 Channel 1 ON.

Control Operator Code  100

Key-up and send: 100 2 1 1

 Zone (1 through 4)
Channel (1 through 8)
Activity (0=OFF 1=ON)

Un-key and the voice will say: "TWO ONE ON."

Repeater Control Channels

Zone 1

1	Repeater Transmit	Enable*
2	Repeater CTCSS	Enable
3	CTCSS and OR	Enable
4	Identification	Enable*
5	Courtesy Tone	Enable*
6	Hang Time	Enable*
7	DTMF Muting	Enable
8	Repeater Time-out	Enable*

Zone 2

1	Link Transmit	Enable*
2	Link CTCSS	Enable
3	Link Receive Only	Enable
4	Link Control	Enable*
5	Link Voice	Enable
6	Link Auto Disconnect	Enable
7	Link To Repeater Output	Enable
8	Link Time-out	Enable*

Zone 3

1	Logic Input #1	Enable*
2	Logic Input #1	Enable*
3	Logic Input #1	Enable*
4	Logic Input #1	Enable*
5	Switch #1	Enable
6	Switch #2	Enable
7	Switch #3	Enable
8	Switch #4	Enable

Zone 4

1	DTMF Pad Test	Enable*
2	Beacon Mode	Enable
3	Weather Report	Enable*
4	Fan Control	Enable
5	Voice ID	Enable*
6	Voice ID Link Inhibit	Enable
7	Forced [D] Key Entry	Enable*
8	CTCSS Encoder Control	Enable

* During initialization these control channels are set to the enable position.

Zone 1 - Repeater Control

1. Repeater Transmitter Enable

This is the master repeater switch. This channel must be enabled for normal repeater operation. The CAT-200B will continue to respond to control operator commands even when the repeater's transmitter is disabled. This channel will automatically be enabled after a dipswitch #7 initialization reset.

2. Repeater CTCSS Enable

When this channel is enabled, in addition to a COR input, an input from a CTCSS decoder at J3-4 must also be present before the repeater will activate. A COR input by itself will have no affect. To prevent loss of control, DO NOT ENABLE THIS CHANNEL unless a CTCSS decoder is connected to J3-4.

3. Repeater CTCSS OR Logic Enable

When this channel is enabled, the COR and CTCSS inputs will function as a (OR) logic input. This means activity on either the COR or CTCSS inputs will cause the controller to key the repeater's transmitter. This is a layered command. Therefore, Repeater CTCSS Enable, Zone 1 Channel 2 must be ON or this control function will have no effect.

4. Repeater ID Enable

When this channel is enabled, repeater voice ID will repeat subject to the setting of the ID timer. This ID will consist of up to 15 words selected from the voice vocabulary table and is programmed with the [*3101] command.

5. Courtesy Tone Enable

When this channel is enabled, a courtesy tone will occur when the COR signal is lost. To eliminate the courtesy tone, turn this channel OFF. The timeout timer will continue to be reset.

6. Transmitter Hang Time Enable

When this channel is enabled, the repeater's transmitter will remain on for a period of time determined by the COR to Beep and Beep to transmitter drop timers. To make the transmitter turn off the instant COR is lost, turn this channel OFF. This feature is useful when linking to other repeaters or during band openings.

7. DTMF Muting Enable

When this channel is enabled, anytime a DTMF tone is received, the audio will be turned off to the repeater's transmitter. The transmit audio will remain muted until a pre-determined time after the last DTMF tone is received. During the mute period, cover beeps are transmitted each second to indicate repeater activity. This feature prevents control commands from being repeated. It provides an extra measure of security. There may be times when it is desirable to pass the DTMF tones through the repeater. To temporarily disable DTMF muting, precede the DTMF string with a (#).

8. Repeater Time-Out Enable

Repeater time-out is user programmable with the [*601*] timer programming commands. When the CAT-200B is initialized, this timer defaults to 3 minutes. When this channel is turned off, the repeater will not time-out.

Zone 2 - Link Control

1. Link Transmitter Enable

This channel must be enabled for link operation. The CAT-200B will respond to the link 5001 on and 5000 off commands. This channel will automatically be enabled after a dipswitch #7 initialization reset.

2. Link CTCSS Enable

When this channel is enabled, in addition to a COR input, an input from a CTCSS decoder at J3-3 must also be present before the repeater will activate. A COR input by itself will have no affect.

3. Link Receive Only Enable

This channel must be enabled for link receive only operation. The CAT-200B will respond to the link receive only 5002 on and 5000 off commands. Any signals received by the link will be heard on the repeater's transmitter. However, conversations on the repeater will not be rebroadcast on the link transmitter.

4. Link Control Enable

The CAT-200B will only respond to the Link control commands [5000] and [5001] through the link input. This greatly reduces the possibility of the CAT-200B responding to a command meant for another repeater in the linking system. When this channel is enabled, link control commands will be accepted through the link receiver input.

5. Link Voice Enable

When this channel is enabled and the link is enabled, voice messages will be transmitted by the transceiver. When this channel is off, PTT #2 will not activate unless repeater COR #1 is active.

6. Link Auto Disconnect Enable

When this channel is enabled, the link will disconnect automatically after a period of repeater inactivity. The voice will say: "LINK TIME OUT". A repeater or transceiver COR will keep the link activate until the repeater returns to rest. A rest period of up to 29 minutes can be selected with the [*604*] programming command. When the CAT-200B is initialized, this timer defaults to 10 minutes.

7. Link To Repeater Output

This channel should be enabled when the transceiver on port 2 is linked to the output of a repeater. The repeater port time-out-timer is reset the instant repeater COR drops. The link port time-out-timer is disabled and the CAT-200B will identify in CW only.

8. Link Time-out Enable

Link time-out is user programmable with the [*602*] timer programming commands. When the CAT-200B is initialized, this timer defaults to 3 minutes. When this channel is turned off, the repeater will not time-out.

Zone 3 - Logic Inputs - Switch Outputs

1. Logic Input #1 Enable

When this channel is enabled, a logic active high input on connector J3-1 will activate voice message #3. This message is user programmable. The default message is "EMERGENCY POWER".

2. Logic Input #2 Enable

When this channel is enabled, a logic high input on connector J3-2 will activate voice message #4. This message is user programmable. The default message is "WEATHER ALERT".

3. Logic Input #3 Enable

When this channel is enabled, a logic high input on connector J3-21 will activate voice message #5. This message is user programmable. The default message is "INTRUDER ALERT".

4. Logic Input #4 Enable

When this channel is enabled, a logic high input on connector J3-22 will activate voice message #6. This message is user programmable. The default message is "HIGH TEMPERATURE".

5. Switch #1 Enable

When this channel is enabled, switch #1 is turned on. Connector J3 pin 14 will sink 50 MA to ground.

6. Switch #2 Enable

When this channel is enabled, switch #2 is turned on. Connector J3 pin 15 will sink 50 MA to ground.

7. Switch #3 Enable

When this channel is enabled, switch #3 is turned on. Connector J3 pin 19 will sink 50 MA to ground.

8. Switch #4 Enable

When this channel is enabled, switch #4 is turned on. Connector J3 pin 20 will sink 50 MA to ground.

Zone 4 - Miscellaneous Control

1. DTMF Pad Test Enable

When this channel is enabled, a repeater user is able to perform a test of their radio's 12 or 16-button keypad. As the numbers are being decoded, they are stored in memory. When the repeater user stops transmitting the controller will read back all the numbers that were decoded.

2. Beacon Mode

When this channel is enabled and there is no activity on the repeater, the CAT-200B will announce voice message 7 at an interval rate determined by the Beacon Timer [*605*]. Message 7 defaults to: "CAT-200B BEACON." The Beacon Timer defaults to one minute.

3. Weather Report Enable

When this channel is enabled, a repeater user is able to request a weather report.

4. Fan Control Enable

When this channel is enabled, and PTT #1 turns ON, the Fan Control output J3-8 will turn ON. After PTT #1 turns OFF this fan control output will remain ON for an additional 60 seconds. Use this output to control a fan relay to cool the repeater's transmitter. When this channel is enabled, User function switch #6 on, off, and momentary operation is not available.

5. Voice Identification Enable

When this channel is enabled, the CAT-200B will identify in voice, using message #1. When this channel is disabled, the CAT-200B will identify in CW only.

6. Voice Identification Link Inhibit Enable

When this channel is enabled, the CAT-200B will not accept an input from the link port while the voice identification is being sent on the repeater port.

7. Forced DTMF Entry D Key

When this channel is enabled it is possible to force a DTMF command even while port #1 is active. To force a DTMF command, end the command with a [D].

8. CTCSS Encoder Switch Enable

When this channel is enabled, user output switch #5 is converted into a CTCSS Encoder Switch output. When Port #1 goes active, user output #5 J2 pin 7 will turn ON. After Port #1 goes inactive, this output will remain ON for an additional period of time. Use this output to control an external CTCSS encoder. When this channel is enabled, User function switch #5 on, off, and momentary operation is not available.

Chapter 4 - Repeater Operation

DTMF Keypad Test

Key-up, and enter [375], the DTMF keypad access code followed by the keypad numbers and letters to be tested. The entries can be in any order. Un-key, and the voice will read-back all numbers and letters that were decoded including the "STAR" and "POUND".

Link Disconnect

Key-up on the repeater's input and enter the link disconnect control number [5000]. The CAT-200B will disconnect the link and the voice will say: "LINK OFF."

Link Connect

Key-up on the repeater's input and enter the link connect control number [5001]. The CAT-200B will connect the repeater and link and the voice will say: "LINK ON."

Link Receive Only

Key-up on the repeater's input and enter the link receive only control number [5002]. The CAT-200B will connect the repeater and link and the voice will say: "LINK RECEIVER ON."

Forced DTMF Command Entry

During normal operation a DTMF command is entered when the port goes inactive. It is possible to force a DTMF command entry even while the port is active. The CAT-200 will accept the [D] key as an entry command.

DTMF Muting Override

With DTMF muting enabled, there may be times when it is desirable to pass the DTMF tones through the repeater or link transmitter. To temporarily disable DTMF muting, precede the DTMF string with a pound (#).

Voice Message Demo

Key-up and enter the voice prefix followed by a message number. The CAT-200B will key the transmitter and say the message stored at that location. Example: With a voice prefix number of 700, play message 3.

Key-up and enter: 7 0 0 0 3
 └──┬──┘ └──┬──┘ Voice Message
 └──┬──┘ Voice Prefix

Weather Report

Key-up and enter the weather report prefix followed by a weather condition number. The CAT-200B will key the transmitter and provide a weather report. Example: With weather prefix number of 200, request the wind speed and direction.

Key-up and enter: 2 0 0 0 3 Weather report Command
 └──┬──┘ └──┬──┘ Wind Speed and Direction Report
 └──┬──┘ Weather Prefix

WEATHER REPORT COMMANDS			
00	Complete Weather Report	03	Wind Speed and Direction Report
01	Inside Temperature Report	04	Rain Fall Report
02	Outside Temperature Report	05	One Minute Wind Speed Report

Chapter 5 - Repeater Programming By DTMF Tone

This section describes how the repeater owner using a DTMF keypad programs the CAT-200B controller. The various types of program commands are described in detail and examples are given in the following text.

Initialization

To initialize the CAT-200B, set dipswitch #7 to on and cycle DC power. During power-up, the voice will say: "RESET SYSTEM OK." Set dipswitch #7 to off. Initialization consists of the following operations:

Dipswitch #7 Initialization

1. All memory locations are cleared.
2. The control channels marked with an [*] are enabled.
3. The unlock number is loaded with the default value [1234567].
4. The control operator prefix code is loaded with [100].
6. The timers are set to default values.
7. The voice ID is loaded with CAT-200B Repeater.

Programming the Unlock Control Number

To program the UNLOCK code, set dipswitch #8 to the on position. The voice will say: "ENTER CONTROL." Key-up and enter a seven-digit number. Un-key, if the number is accepted, the voice will say: "CONTROL OK." If the number is rejected, the voice will say: "ENTER CONTROL." Key-up and enter the seven-digit number. Set dipswitch #8 to the off position.

Unlocking the Controller By Radio [1234567]

To unlock the controller, key-up and enter the seven digit unlock number. The voice will say: "CAT 200 CONTROL."

Locking the Controller By Radio [*0]

Key-up and send [*0]. Un-key, the controller will lockup and the voice will say: "CONTROL EXIT." The controller will lock-up automatically when the programming timer expires. The voice will say: "TIMER EXIT." The programming time limit is set for ten minutes.

NOTE: The CAT-200B must be unlocked to perform the following programming functions.

Send Synthesized Voice Message [*3001]-[*3012]

Key-up and send [*3001]. Un-key and the voice synthesizer will say the ID.

Program Synthesized Voice Message [*3101]-[*3112]

Key-up and send [*3101] followed by the three digit numbers that represents the words required to construct the ID. Memory space is provided for 15 entries. Refer to the Voice Vocabulary Word List. Example: Load Repeater ID with "W4XYZ Repeater"

Message Number	W	4	X	Y	Z	Repeater
Programming	890	004	920	930	950	746
Command	*31	01				

VOICE MESSAGE NUMBER TABLE			
01	Repeater ID Message	07	Beacon Message
02	Weather Report Message	08	Link Connect Message
03	Voice Message #3	09	Link Disconnect Message
04	Voice Message #4	10	Link Auto Disconnect Message
05	Voice Message #5	11	Voice Message #11
06	Voice Message #6	12	Voice Message #12

Erase Synthesized Voice Message [*3201]-[*3212]

Key-up and send [*32XX]. Un-key and the voice will say: "CONTROL OK." The voice message will be erased.

CW ID Memory Storage

Memory space is provided for a CW identification. The buffer will accept 16 characters. If a repeater user talks over the voice ID, the CAT-200B will switch to the CW ID. If Zone 4 Channel 5 is disabled, the controller will ID in CW only. During initialization, the CW buffer is loaded with "CAT200/R."

Send Repeater CW ID [*33]

Key-up and send [*33]. Un-key and the CAT-200B will send the CW ID.

Program Repeater CW ID [*34]

Key-up and send [*34], followed by the two digit numbers that represents the call letter identification. Memory space is provided for (16) entries. Refer to the CW ID programming table. Example: Load CW ID memory buffer with DE W4XYZ/R.

```

Programming Command  *34  D  E  SPACE  W  4  X  Y  Z  /  R
                        13  14  38   32  04  33  34  35  36  27

```

CW ID PROGRAMMING TABLE							
00=ZERO	05=FIVE	10=A	15=F	20=K	25=P	30=U	35=Z
01=ONE	06=SIX	11=B	16=G	21=L	26=Q	31=V	36=/
02=TWO	07=SEVEN	12=C	17=H	22=M	27=R	32=W	
03=THREE	08=EIGHT	13=D	18=I	23=N	28=S	33=X	
04=FOUR	09=NINE	14=E	19=J	24=O	29=T	34=Y	

Erase Repeater CW ID [*35]

Key-up and send [*35]. Un-key and the voice will say: "CONTROL OK." If the CW ID buffer is empty and a repeater user keys-up during a voice ID, the voice ID will stop.

Control Code And Prefix Number Memory

This memory area is reserved for storage of control and prefix numbers. These numbers can be from one to seven digits and will change to a default value when the CAT-200B is powered up with dip-switch #7 set to the on position.

Control Operator Prefix Number Repeater [*501*]

This programming command selects the control operator prefix number for the repeater port. This number must precede the command to change the zone control channels. Example: To program a Control Operator Prefix of [100], key-up and send:

Programming Command Control Operator Prefix Number
 501 100

Un-key, the voice will say: "CONTROL OK." The default number is [100].

Voice Demonstration Control Number [*502*]

This number must be entered to PLAY one of the voice messages. This number must precede the voice message number. Example: To program a Voice Demonstration Control Number of 700, key-up and send [*502*700]. Un-key and the voice will say: "CONTROL OK."

DTMF Pad Test Number [*503*]

This number must be entered to initiate a DTMF keypad test. Example: To program a DTMF Pad Test Number of 375, key-up and send [*503*375]. Un-key and the voice will say: "CONTROL OK."

Weather Report Control Number [*504*]

This number must be entered to initiate a weather report. Example: To program a weather report Control Number of 200, key-up and send [*504*200]. Un-key and the voice will say: "CONTROL OK."

Link Disconnect Control Number [*505*]

This number is used to disconnect the link. Example: To program a link disconnect control number of 5000, key-up and send [*505*5000]. Un-key and the voice will say: "CONTROL OK."

Link Connect Control Number [*506*]

This number is used to connect the link. Example: To program a link connect control number of 5001, key-up and send [*506*5001]. Un-key and the voice will say: "CONTROL OK."

Link Receive Only Control Number [*507*]

This number is used to activate the link receive only mode. Example: To program a link receive only control number of 5002, key-up and send [*507*5002]. Un-key and the voice will say: "CONTROL OK."

Control Operator Prefix Number Link [*508*]

This programming command selects the control operator prefix number for the link port. This number must precede the command to change the zone control channels. To program a Control Operator Prefix of [300], key-up and send [*508*300]. Un-key, the voice will say: "CONTROL OK." The default number is [300].

Read Control And Prefix Numbers [*501 - *508]

Use this programming command to read the control operator and prefix numbers. Example: Key-up and enter [*501], un-key and the voice will say: "CODE FIVE ZERO ONE IS ONE ZERO ZERO."

Timer Memory

This memory area is reserved for storage of [8] timers. These timers are user programmable. When the CAT-200B is initialized, these timers are automatically loaded with default values.

Repeater Time-out [*601*]

This timer limits the length of a transmission. This timer is programmable between 60 and 1799 seconds. Example: To program the timer for 3 minutes, key-up and enter [*601*180]. Un-key and the voice will say: "CONTROL OK." When initialize, this timer defaults to 180 seconds.

Link Time-out [*602*]

The link time-out timer limits the maximum length of a transmission. This timer is programmable between 60 and 1799 seconds. Example: To program the timer for 3 minutes, key-up and enter [*602*180]. Un-key and the voice will say: "CONTROL OK." When initialize, this timer defaults to 180 seconds.

Repeater ID Timer [*603*]

This timer sets the time between transmissions of the repeater ID. The ID occurs when a repeater user stops transmitting. This timer is programmable between 60 and 1799 seconds. The timer default is 480 seconds.

Link Auto Disconnect Timer [*604*]

During link operation if Zone 2 channel 6 is enabled the link will disconnect automatically after a period inactivity. This timer is programmable between 60 and 1799 seconds. The timer default is 600 seconds.

Beacon Mode Timer [*605*]

When Zone 4 channel 2 is enabled and the repeater is inactive, the CAT-200B will automatically transmit voice message 7. The message will repeat per the setting of this timer. This timer is programmable between 60 and 1799 seconds. The timer default is 60 seconds.

Logic Input Message Timer [*606*]

This timer sets the time between logic input message announcements. The messages will continue to repeat as long as the respective logic input remains active high. This timer is programmable between 60 and 1799 seconds. The timer default is 600 seconds.

COR Drop to Courtesy Beep Timer [*610*]

This timer determines the time between loss of COR and the generation of the courtesy beep. This timer is programmable between 0.1 and 9.9 seconds. The timer default is 1 second.

Courtesy Beep to PTT Drop Timer [*611*]

This timer determines the time between the generation of the courtesy beep and the time the repeater transmitter turns off. This timer is programmable between 0.1 and 9.9 seconds. The timer default is 4 seconds.

Read Timer Settings [*601 - *611]

Key-up and send [*601]. Un-key and the voice synthesizer will read back the setting of the repeater's time-out timer. The voice will say: "TIMER 60 IS THREE MINUTES."

Audio Test Tone [*91 - *92 - *93]

The CAT-200B will generate a 1000Hz test tone. Use this tone as a reference when setting audio levels. To activate the tone, as TX1 audio, key-up and enter [*91]. To activate the tone, as TX2 audio, key-up and enter [*92]. To activate the tone, as TX1 and TX2 audio, key-up and enter [*93].

Program Repeater Courtesy Tone [*940 - *946]

The CAT-200B will generate this courtesy tone each time there is loss of signal by the repeater receiver and the link is turned OFF.

Program Repeater Courtesy Tone [*950 - *956]

The CAT-200B will generate this courtesy tone each time there is loss of signal by the repeater receiver and the link is turned ON.

Program Link Courtesy Tone [*960 - *966]

The CAT-200B will generate this courtesy tone each time there is loss of signal by the link receiver.

Program Link Courtesy Tone [*970 - *976]

The CAT-200B will generate this courtesy tone each time there is loss of signal by the link receiver and the link is in the receive only mode.

TONE	FREQUENCY #1	FREQUENCY #2	TONE	FREQUENCY #1	FREQUENCY #2
0	NONE	NONE	4	800Hz	800Hz
1	1000Hz	NONE	5	800Hz	1000Hz
2	800Hz	NONE	6	1000Hz	800Hz
3	1000Hz	1000Hz			

Exit Programming Mode [*0]

To exit the programming mode and return to normal repeater operation, key-up and send [*0]. Un-key and the voice will say: "CONTROLL EXIT." If you fail to exit the programming mode, the CAT-200B will return to normal repeater operation. The voice will say: "TIMER EXIT."

DTMF Programming Commands (Repeater)

ENTRY	DESCRIPTION	DEFAULT
*27	READ WEATHER STATION DATA SETTING	
*30XX	SEND VOICE MESSAGE (01-12)	
*31XX	PROGRAM VOICE MESSAGE (01-12)	
*32XX	ERASE VOICE MESSAGE (01-12)	
501	PROGRAM CONTROL OPERATOR NUMBER (REPEATER INPUT)	100
502	PROGRAM VOICE DEMONSTRATION PREFIX	700
503	PROGRAM DTMF PAD TEST NUMBER	375
504	PROGRAM WEATHER REPORT PREFIX	200
505	PROGRAM LINK DISCONNECT NUMBER	5000
506	PROGRAM LINK CONNECT NUMBER	5001
507	PROGRAM LINK RECEIVE ONLY NUMBER	5002
508	PROGRAM CONTROL OPERATOR NUMBER (LINK INPUT)	300
601	PROGRAM REPEATER TIME-OUT TIMER (60 - 1799 SECONDS)	300
602	PROGRAM LINK TIME-OUT TIMER (60 - 1799 SECONDS)	300
603	PROGRAM REPEATER ID TIMER (60 - 1799 SECONDS)	480
604	PROGRAM LINK AUTO DISCONNECT TIMER (60 - 1799 SECONDS)	600
605	PROGRAM BEACON MODE TIMER (60-1799 SECONDS)	60
606	PROGRAM LOGIC INPUT MESSAGE TIMER (60-1799 SECONDS)	600
610	PROGRAM COR DROP TO COURTESY BEEP TIMER (0.1 - 9.9 SECONDS)	1.0
611	PROGRAM COURTESY BEEP TO PTT DROP TIMER (0.1 - 9.9 SECONDS)	4.0
*91	TRANSMIT AUDIO TEST TONE (REPEATER)	
*92	TRANSMIT AUDIO TEST TONE (LINK)	
*93	TRANSMIT AUDIO TEST TONE (REPEATER + LINK)	
*9X	READ COURTESY TONE (4-5-6-7)	
*94X	PROGRAM REPEATER COURTESY TONE (0-6)	TONE 5
*95X	PROGRAM REPEATER COURTESY TONE WITH LINK ENABLED (0-6)	TONE 1
*96X	PROGRAM LINK COURTESY TONE (0-6)	TONE 2
*97X	PROGRAM LINK COURTESY TONE WITH LINK IN RECEIVE ONLY (0-6)	TONE 4
*0	MANUAL EXIT OF PROGRAMMING MODE	

Chapter 6 - Interfacing to Other Equipment

Interfacing the CAT-200B to your repeater system is a simple matter. A minimum of two inputs and two outputs are required for the CAT-200B to control a repeater. They are:

1. A COR signal to indicate when a signal is being received.
2. A receive audio signal containing DTMF tones to be processed for control.
3. A Push-To-Talk signal to tell the repeater transmitter to turn ON.
4. A transmit audio signal containing a combination of receive audio, synthesized voice, and courtesy tone.

Additional connections are required to realize all features of the CAT-200B.

Determining COR Logic

Locate your repeater receiver's COR output. This line has a DC voltage that changes state when a signal is being received. If the COR line is 0 volts and goes to a positive voltage when a signal is received it is said to be (positive logic) or active HIGH. If the COR line is a positive voltage, and goes to 0 volts when a signal is received it is said to be (negative logic) or active LOW. Note: 0 volts is any voltage less than 0.8VDC. A positive voltage is any voltage greater than 3.0VDC. Set dipswitch #1 on the CAT-200B to ON for (negative logic) and OFF for (positive logic).

Connection to Receiver

Connect the repeater receiver audio output to J3-13 and the COR to J3-6 of the CAT-200B. Verify this line changes from less than 0.8VDC to greater than 3.0 VDC. If the COR line will not meet these limits it may be necessary to add a pull-up resistor to the COR #1 line. This may also be true for the COR #2 input. Space is provided on the CAT-200B board to add pull-up resistors.

Connection to Transmitter

Locate your repeater's Push-To-Talk input. When grounded, this line will make the repeater transmit. Connect the CAT-200B PTT #1 output (J3-10) to this line. Locate your repeater's TX audio input. This is the line where the audio signal used to modulate the transmitter is applied. Connect the TX1 AUDIO (J3-11) to this line.

Connection to CTCSS Decoder

If your repeater receiver has a CTCSS decoder output, connect it to J3-4. In addition to COR, the CAT-200B requires an active high input to represent a CTCSS input. If the CTCSS input is active low set dipswitch #2 on.

Interface Review

1. Are dipswitches #1 through #8 in their proper positions?
2. Is the PTT-1 output at J3-10 connected to the transmitter PTT input?
3. Is the TX1 Audio at J3-11 connected to the transmitter audio input?
4. Is the COR-1 at J3-6 connected to the repeater receiver COR output?
5. Is dipswitch #1 ON for active low COR or OFF for active high COR?
6. Is the COR level changing from less than 0.8 VDC to greater than 3.0 VDC?
7. Is the RX1 AUDIO at J3-13 connected to the receiver audio output?
8. Is the audio input level sufficient for the DTMF decoder?

Connector Kit

Included with the controller is a connector kit containing a 25 pin "D" connector to mate with J3, a 2.5mm power plug to mate with J2 (center pin is [+]), two 2200 ohm resistors and two .0047uF capacitors. If the COR inputs are active low, install the 2200 ohm resistors as pull-ups on the board at the R36 and R37 positions. If the receiver's COR circuit is not capable of pulling down the 2200 ohm resistor increase the resistor value to 10K ohms. If the controller is supplied with discriminator audio install the .0047uF capacitors on the board at the C10 and C11 positions to de-emphasize the audio.

Power Supply

The CAT-200B is powered by an external 12VDC power supply. Connect the positive lead of the supply to the center pin of the coaxial power connector J2 and the negative lead to the outer conductor.

Audio Level Adjustment

The audio mixing-switching circuits of the CAT-200B are optimized around an input and output of -10dBm (220mV).

Connect a signal generator to the repeater's receiver input. Adjust the signal generator's output for a standard test signal of 1000 Hz at 3 KHz deviation. If a signal generator is not available, select a handi-talkie that you suspect has the DTMF tone pad adjusted for approximately 3 KHz deviation.

Key-up on the repeater input and send a DTMF tone. Adjust the RX1 control R10 for 220 mVAC at TP1. If a link transceiver is connected to the CAT-200B, key-up and send the LINK enable command [5001]. Key-up on the LINK receiver input and send a DTMF tone. Adjust RX2 control R16 for 220 mVAC at TP1.

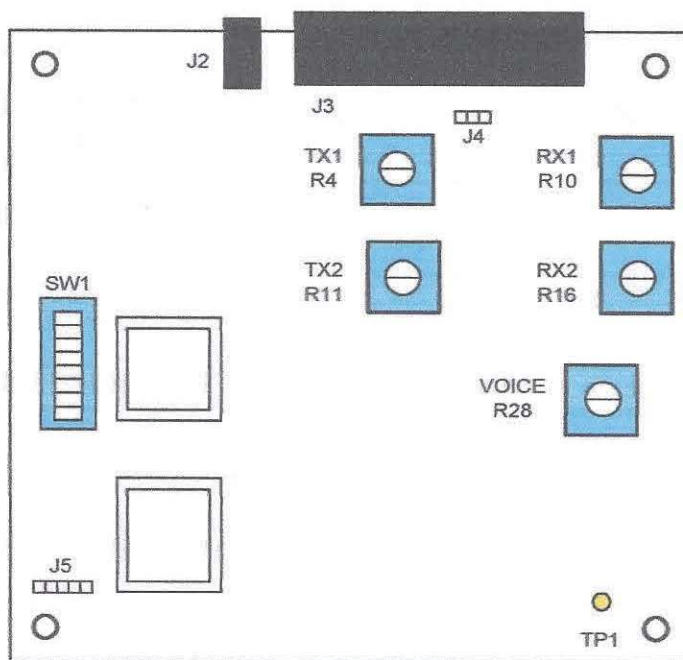

Figure 6-1

Once the RX1, and RX2 audios are adjusted, key-up on the repeater input and send a DTMF tone. Monitor the REPEATER transmitter. Adjust the TX1 Audio level control (R4) as required to set the repeater transmitter deviation to 3 KHz or as desired. If the repeaters transmit audio input is very sensitive and you find the TX1 Audio level control near minimum, it is strongly recommended that an external voltage divider be installed at the audio input of the repeater's transmitter.

If a link transceiver is connected, key-up on the repeater input and send a DTMF tone. Monitor the LINK transmitter. Adjust the TX2 Audio level control (R11) as required to set the link transmitter deviation to 3 KHz or as desired.

If the link transmit audio input is very sensitive and you find the TX2 Audio level control is near minimum, set the jumper plug at J4 between pins 1 and 2.

Compare the receive and synthesized voice audio and adjust the voice Level (R28) as desired. The synthesized voice should be slightly lower than the receive audio.

Unlock the CAT-200B by keying-up on the repeater input and entering: [1234567]. Key-up and enter the [*91] test tone programming command. Verify that the test tone provides approximately 1.5 KHz transmitter deviation. Key-up and enter [*0] to exit the programming mode.

Test Point TP1 - Receiver Audio

This test point displays the receive audio level at the input of the DTMF decoder. Adjust RX1 and RX2 for 200mVAC of DTMF audio.

Repeater Interface (J3)

Connector J3 provides an interface to the repeater and transceiver.

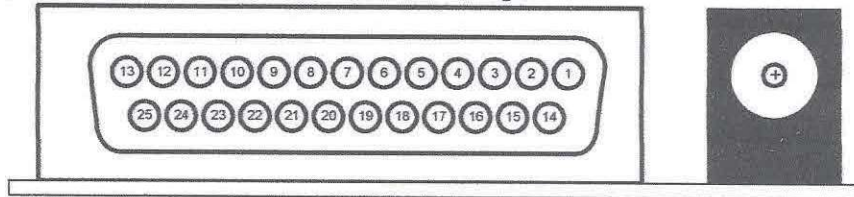

1. LOGIC INPUT #1	10. PTT #1	19. SWITCH #3
2. LOGIC INPUT #2	11. TX AUDIO #1	20. SWITCH #4
3. CTCSS #2	12. RX AUDIO #2	21. LOGIC INPUT #3
4. CTCSS #1	13. RX AUDIO #1	22. LOGIC INPUT #4
5. COR #2	14. SWITCH #1	23. TX AUDIO #2
6. COR #1	15. SWITCH #2	24. RESERVED
7. CTCSS ENCODER SWITCH	16. +12VDC OUTPUT	25. GROUND
8. FAN CONTROL	17. GROUND	
9. PTT #2	18. GROUND	

Figure 6-2

Weather Station Interface (J5)

Connector J5 provides an interface to the CI-200 Interface Board.

1. +12VDC	2. GROUND	3. +5VDC	4. RX DATA	5. TX DATA
-----------	-----------	----------	------------	------------

Figure 6-3

CTCSS Decoder

Connect the TS-64 CTCSS Encoder/Decoder assembly to the CAT-200B as described in Figure 6-5. The decoder must be connected to discriminator audio. Speaker or volume control audio will have insufficient low frequency CTCSS tone content.

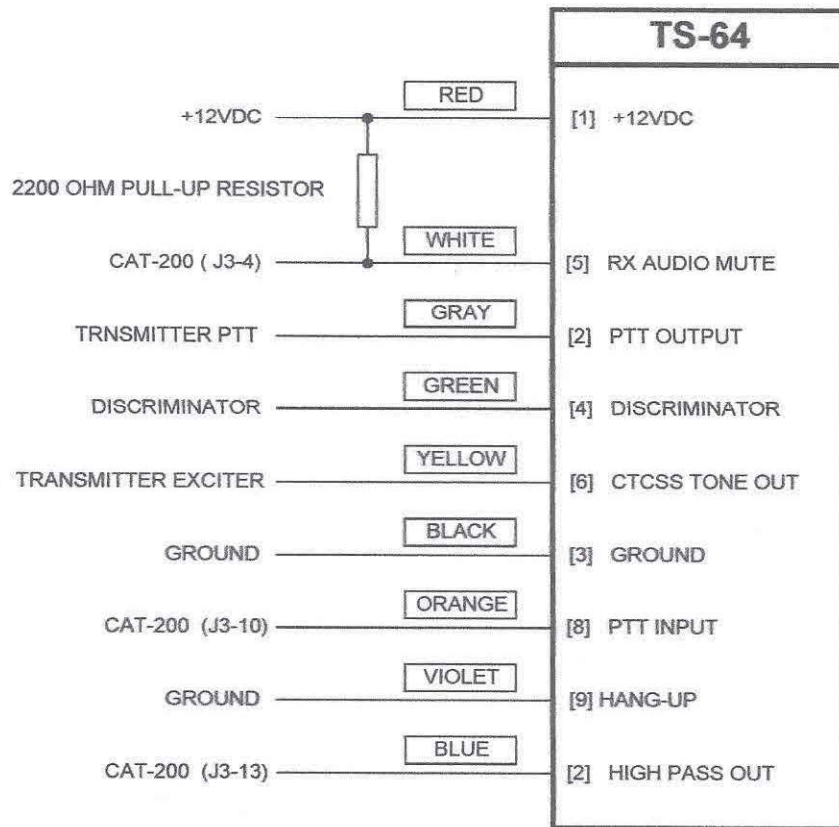

Figure 6-5

Connector Kit

The connector kit contains a DB25 male connector with hood, a 2.5 mm DC power plug, two 2200-ohm pull-up resistors and two .0047uF capacitors. If the CAT-200B is supplied with discriminator audio, install the .0047uF capacitor on the board at position C10 or C11 in the case of the link receiver. If required install the 2200 ohm resistors on the CAT-200B board to pull-up the COR inputs.

Chapter 7 - Weather Station Interface

Provide timely weather announcements on your repeater system. Connect a Peet Brothers Ultimeter ® U-100, U-800 or U-2000 Weather Station to the serial port of the CAT-200B. Integrate temperature, wind speed, direction, and rainfall rate into any of the CAT-200B voice messages. Program a special weather report message as part of your identification.

Peet Brothers Weather Station Setup

Connect the weather station component cables as described in the weather station owner's manual. Install the 9 volt battery. If will be necessary to set the weather station's clock.

Peet Brothers Interconnect

Purchase a four-conductor telephone cable. Hold the modular connector with the latch down and the gold contacts up. Check that the black wire is on the left side of the modular connector. Cut the modular connector off of the other end of the telephone cable. Strip the cable and cut off the red and yellow wires. Strip the green and black wires.

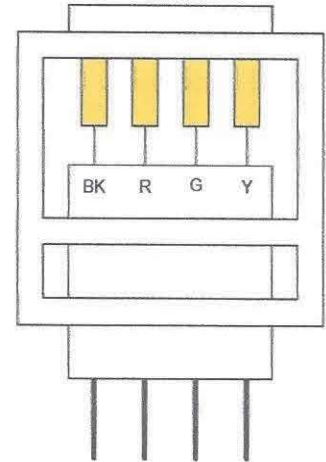

CAT-200B - Weather Station Interface

Connect your Peet Brothers Weather Station to the CI-200 as described in Figure 7-1. On the CI-200 set the J2 jumper plug to the WS position. On the CAT-200B set dipswitch #6 to ON. Set Zone 4 Channel 3 to on to enable weather station information.

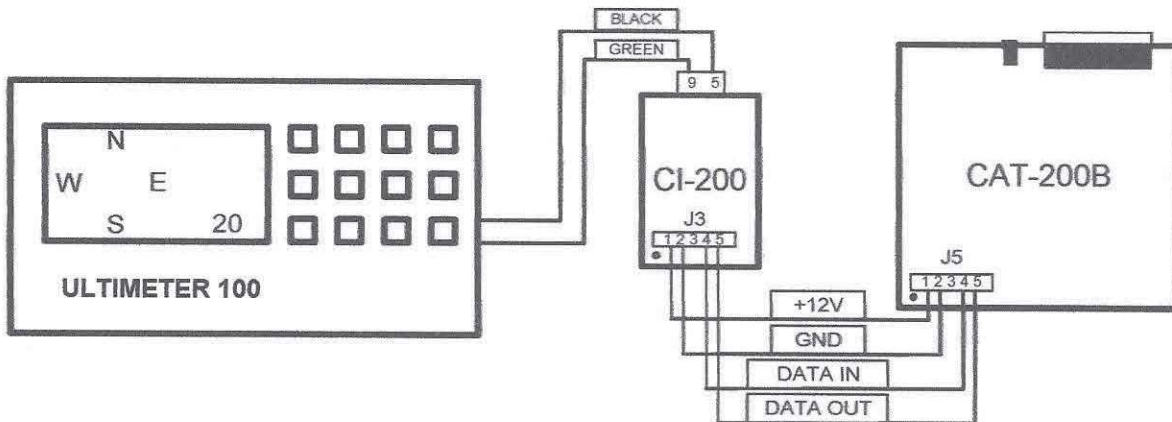

Figure 7-1

To provide continuous weather information to the CAT-200B, the weather station must be in the "LONG DATA MODE." On the keyboard display unit: press and hold the [CLEAR] and [RAIN FALL] keys for three seconds.

To test the interface, unlock the CAT-200B and enter the [*27] programming command. If the controller is receiving data, the voice synthesizer will say: "LONG DATA VERIFY." If a problem exists the voice will say "ERROR NO DATA."

Weather Report

Key-up and enter the weather report prefix followed by a weather condition number. The CAT-200B will key the transmitter and provide a weather report. Example: With weather prefix number of 200, request the wind speed and direction.

Key-up and enter: 2 0 0 0 3 Weather report Command
 └─┬─┘ └─┬─┘ Wind Speed and Direction Report
 └─┬─┘ Weather Prefix

WEATHER REPORT COMMANDS	
00	Complete Weather Report
01	Inside Temperature Report
02	Outside Temperature Report
03	Wind Speed and Direction Report
04	Rain Fall Report
05	Five Minute Peak Wind Speed Report
06	High and Low Temperature
07	Wind Chill
08	Air Pressure (Not Available in U-100)
09	Humidity (Not Available in U-100)